



LMP-1600G-M12-67-110 Series

16-Port Industrial M12 IP67 Waterproof Gigabit PoE+ Light Layer 3 Managed Ethernet Switch, with 16*10/100/1000Tx M12 Connectors (X-Coded) (30W/Port), 24~110VDC Power Input



Hardware Manual

Version 1.0
(December 2021)



© Copyright 2021 Antaira Technologies, LLC

All rights reserved

This document contains information, which is protected by copyright. Reproduction, adaptation, or translation without prior permission is prohibited, except as allowed under the copyright laws.

Trademark Information

Antaira is a registered trademark of Antaira Technologies, LLC, Microsoft Windows and the Windows logo are the trademarks of Microsoft Corp. NetWare is the registered trademark of Novell Inc. WMM and WPA are the registered trademarks of Wi-Fi Alliance. All other brand and product names are trademarks or registered trademarks of their respective owners.

Notice: Copyrights © 2021 by Antaira Technologies, LLC. All rights reserved. Reproduction, adaptation, or translation without prior permission of Antaira Technologies, LLC is prohibited, except as allowed under the copyright laws.

Disclaimer

Antaira Technologies, LLC provides this manual without warranty of any kind, expressed or implied, including but not limited to the implied warranties of merchantability and fitness for a particular purpose. Antaira Technologies, LLC may make improvements and/or changes to the product and/or specifications of the product described in this manual, without prior notice. Antaira Technologies, LLC will not be liable for any technical inaccuracies or typographical errors found in this guide. Changes are periodically made to the information contained herein and will be incorporated into later versions of the manual. The information contained is subject to change without prior notice.

FCC Warning

This equipment has been tested and found to comply with the limits for a Class-A digital device, pursuant to Part 15 of the FCC rules. These limits are designed to provide reasonable protection against harmful interference in a residential installation. This equipment generates, uses, and can radiate radio frequency energy. It may cause harmful interference to radio communications if the equipment is not installed and used in accordance with the instructions. However, there is no guarantee that interference will not occur in a particular installation. If this equipment does cause harmful interference to radio or television reception, which can be determined by turning the equipment off and on, the user is encouraged to try to correct the interference by one or more of the following measures:

- Reorient or relocate the receiving antenna.
- Increase the separation between the equipment and receiver.
- Connect the equipment into an outlet on a circuit different from that to which the receiver is connected.
- Consult the dealer or an experienced radio/TV technician for help.

Caution: Any changes or modifications not expressly approved by the grantee of this device could void the user's authority to operate the equipment.

Avertissement FCC

Cet équipement a été testé et déclaré conforme aux limites d'un appareil numérique de classe A, conformément à la partie 15 des règles de la FCC. Ces limites sont conçues pour fournir une protection raisonnable contre les interférences nuisibles dans une installation résidentielle. Cet équipement génère, utilise et peut émettre de l'énergie radiofréquence. Cela peut provoquer des interférences nuisibles aux communications radio si l'équipement n'est pas installé et utilisé conformément aux instructions. Cependant, il n'y a aucune garantie qu'aucune interférence ne se produira dans une installation particulière. Si cet équipement provoque des interférences nuisibles à la réception radio ou télévision, ce qui peut être déterminé en éteignant puis en rallumant l'équipement, l'utilisateur est encouragé à essayer de corriger les interférences par une ou plusieurs des mesures suivantes:

- Réorientez ou déplacez l'antenne de réception.
- Augmentez la distance entre l'équipement et le récepteur.
- Connectez l'équipement à une prise sur un circuit différent de celui auquel le récepteur est connecté.
- Consultez le revendeur ou un technicien radio / TV expérimenté pour obtenir de l'aide.

CE Mark Warning

This is a Class-A product. In a domestic environment, this product may cause radio interference in which case the user may be required to take adequate measures.

Avertissement de marque CE

Ceci est un produit de classe A. Dans un environnement domestique, ce produit peut provoquer des interférences radio, auquel cas l'utilisateur peut être amené à prendre des mesures adéquates.

Industrial Ethernet Switches

Industrial Grade Managed Ethernet Switches

Hardware Manual

Version 1.0 (December 2021)

The manual supports the following models:

- LMP-1600G-M12-67-110
- LMP-1600G-M12-67-110-T

Antaira Technologies - Industrial Ethernet Switches
LMP-1600G-M12-67-110 Series - Hardware Manual - v1.0

This document is the current official release hardware manual. Please check our website (www.antaيرا.com) for any updated manual or contact us by e-mail (support@antaيرا.com).

Table of Contents

| | |
|-------------------------------------|-----------|
| 1 Overview | 6 |
| 1.1 Product Hardware Features | 6 |
| 1.2 Product Software Features | 7 |
| 1.3 Package Contents | 7 |
| 1.4 Safety Precaution | 8 |
| 2 Hardware Description | 9 |
| 2.1 Physical Dimensions | 9 |
| 2.2 Front View Panel | 10 |
| 2.3 LED Indicators | 11 |
| 2.4 Reset to Default | 12 |
| 2.5 Ethernet Ports | 12 |
| 2.6 USB Port | 14 |
| 2.7 Console Port | 14 |
| 2.8 Power Inputs | 15 |
| 2.9 Relay Contact and Digital Input | 15 |
| 2.10 Grounding Note | 17 |
| 2.11 Bypass Function | 18 |
| 3 Mounting Installation | 19 |
| 3.1 Wall Mounting | 19 |
| 4 Hardware Installation | 21 |
| 4.1 Installation Steps | 21 |
| 4.2 Maintenance and Service | 22 |
| 4.3 Troubleshooting | 22 |
| 5 Technical Specifications | 23 |

1 Overview

Antaira Technologies' LMP-1600G-M12-67-110 Series is an 18-port managed gigabit Ethernet switch, which provides 16*10/100/1000 Base-T(X) with IEEE 802.3 af/at PoE compliant. LMP-1600G-M12-67-110 Series is a fully manageable light layer 3 Ethernet switch series and supports power inputs redundancy. LMP-1600G-M12-67-110 Series offers standardized network redundancy ITU-T G.8032 ERPS v2 (Ethernet Ring Protection Switch) protocol, providing <50ms recovery time to the network.

LMP-1600G-M12-67-110 Series provides comprehensive network security and management capability by supporting Multi-user accounts, IGMP, GVRP, VLAN, QoS, SNMP, RADIUS, TACACS+, Aggregation (Static, LACP), SSH, SSL, IP source guard to create a highly-secured network environment. For power saving purposes, assuring PD priority, and enhancing the security level of the network, LMP-1600G-M12-67-110 Series also supports PoE scheduling and PoE output limit function to set up PoE output duration and watt at will.

LMP-1600G-M12-67-110 Series is an M12 IP67 PoE+ industrial gigabit Ethernet switch that meets the high-reliability requirements demanded by industrial applications. Its M12 connectors ensure a tight and robust connection and it guarantees reliable operation on applications that are subject to high vibration and shock in dust, liquid or gas-laden environments. Being able to operate under the standard temperature range from -10°C to 65°C or the extended temperature range from -40°C to 70°C, the LMP-1600G-M12-67-110 Series can be installed in almost any harsh environment.

1.1 Product Hardware Features

System Interface and Performance

- All M12 ports support Auto MDI/MDI-X Function
- M12 connector with IP67 rated protection
- Store-and-forward switching architecture

Power Input

- DC 24~110V redundant
- The power input specification complies with the requirements of SELV (Safety Extra Low Voltage) and the power supply should comply with UL 61010-1 & UL 61010-2-201

Operating Temperature

- LMP-1600G-M12-67-110: -10°C to 65°C
- LMP-1600G-M12-67-110-T: -40°C to 75°C

Case / Installation

- IP67 protection metal housing

- Wall-mount design
- Installation in a Pollution Degree 2 industrial environment

1.2 Product Software Features

Network Redundancy

- STP, RSTP, MSTP, ITU-T G.8032 Ethernet Ring Protection Switch (ERPS) for network redundancy

Network Management

- Web UI based management, SNMP v1/v2/v3, Serial Console
- QoS, traffic classification QoS, Cos, bandwidth control for Ingress and Egress, broadcast storm control, Diffserv
- IEEE 802.1q VLAN tagging, port-based VLAN support
- IGMP snooping v1/v2/v3, IGMP filtering/throttling, IGMP query up to 1024 group
- Supports IPv4/IPv6, RMON, MIB II, port mirroring, event Syslog, DNS, NTP/SNTP, HTTPS, SSH/SSL, TFTP
- MODBUS TCP for SCADA system integration

Port Configuration

- Status, statistics, mirroring, rate limiting, event Syslog

Event Handling

- Event notification: Cold/Warm Start, Power Failure, Authentication, SNMP trap, and Fault Alarm Relay Output

Storage Upgrade via TFTP and HTTP

Configuration Backup - USB Port

1.3 Package Contents

- LMP-1600G-M12-67-110(-T)
- Quick Installation Guide
- Dust cover set

1.4 Safety Precaution

Attention: If the DC voltage is supplied by an external circuit, please use a protection device on the power supply input. The industrial Ethernet switch's hardware specs, ports, cabling information, and wiring installation will be described within this hardware manual.

Attention: Si la tension CC est fournie par un circuit externe, veuillez utiliser un dispositif de protection sur l'entrée d'alimentation. Les spécifications matérielles, les ports, les informations de câblage et l'installation du câblage du commutateur Ethernet industriel seront décrits dans ce manuel d'utilisation.

Warning Labels

The caution label means that you should check certain information on the user manual when working with the device. (Shown in *Figure 1.1*)

Étiquettes d'avertissement

L'étiquette d'avertissement signifie que vous devez vérifier certaines informations du manuel d'utilisation lorsque vous travaillez avec l'appareil. (Illustré à la *figure 1.1*)



Figure 1.1 - Caution Label
Figure 1.1 - Étiquette de mise en garde



Figure 1.2 - Hot Surface Warning Label
Figure 1.2 - Étiquette d'avertissement de surface chaude

2 Hardware Description

2.1 Physical Dimensions

Figure 2.1, below, shows the physical dimensions of this product series:

(W x D x H) is 166.2mm x 295mm x 101.3mm

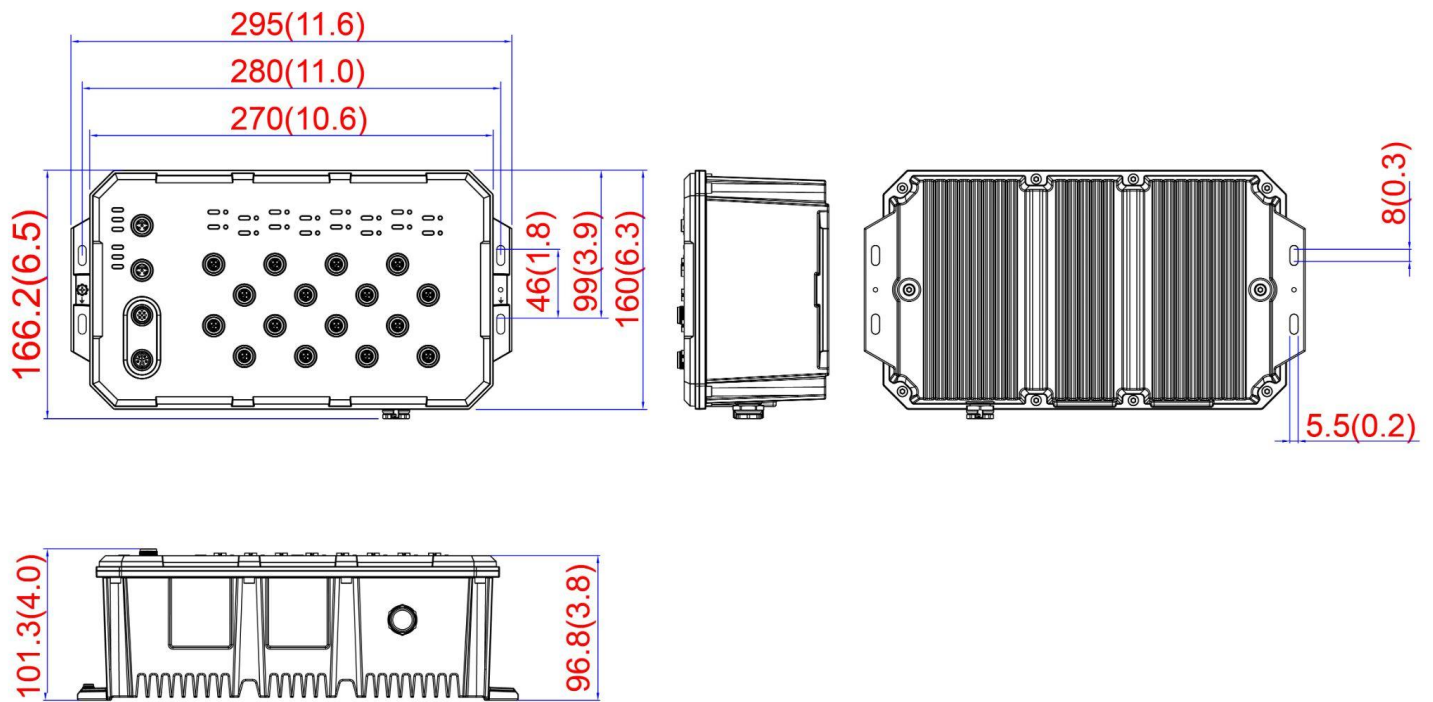

Unit: mm (inch)

Figure 2.1 - Physical Dimensions

2.2 Front View Panel

Figure 2.2, below, shows the front panel of the product series:

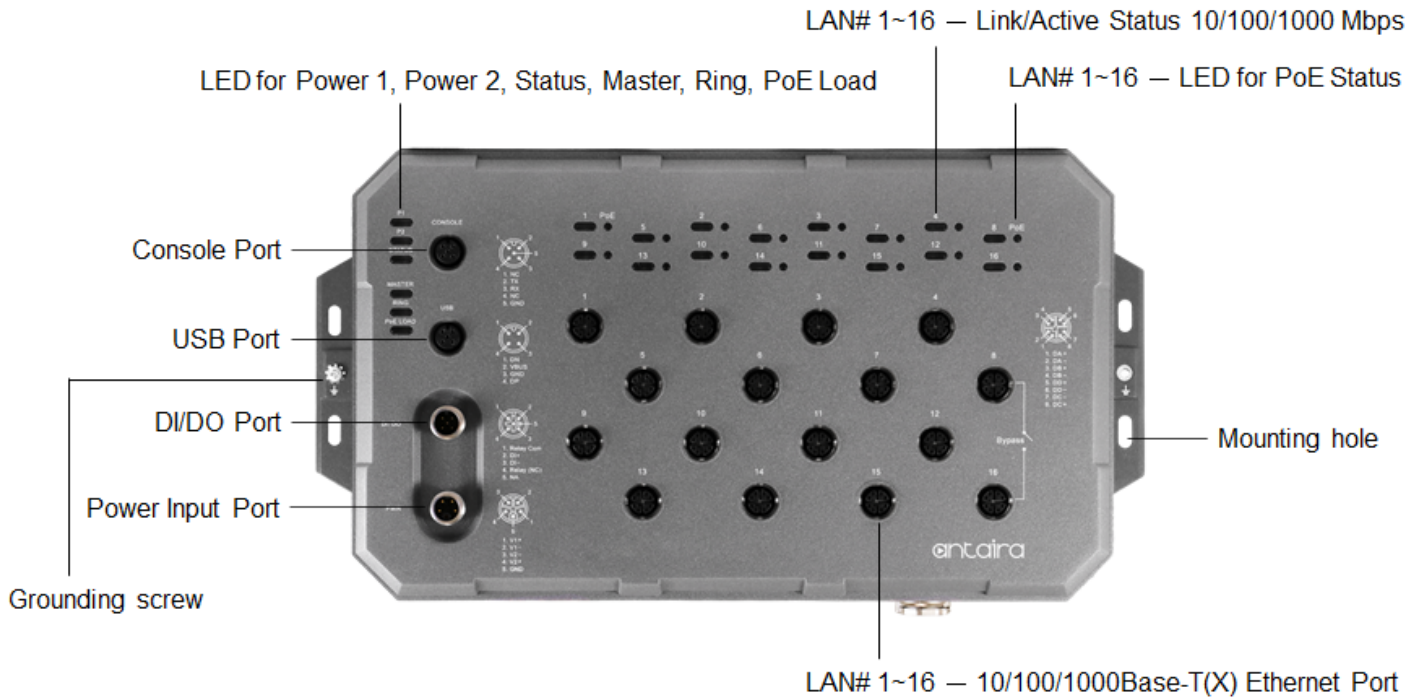

Figure 2.2 - Front View Panel

2.3 LED Indicators

There are LED light indicators located on the front panel of the industrial Ethernet switch that display the power status and network status. Each LED indicator has a different color and has its specific meaning, see below in *Table 2.1*.

| LED | Color | Description | |
|---------------|--|-------------|--|
| P1 | Green | On | Power Input 1 is active |
| | | Off | Power Input 1 is inactive |
| P2 | Green | On | Power Input 2 is active |
| | | Off | Power Input 2 is inactive |
| Status | Green | On | The system is ready and works fine. No events are occurring. |
| | Red | Flashing | Firmware upgrading |
| | | On | System booting or configured event happens |
| Master | Green | On | ERPS Owner Mode (Ring Master) is ready |
| | | Off | ERPS Owner Mode is not active |
| Ring | Green | On | Ring Network is active |
| | | Flashing | ERPS Ring works abnormally or misconfigured |
| | | Off | Ring Network is not active |
| PoE Load | Off | Off | PoE Load ≤ 50% |
| | Blue | On | PoE Load 51 - 70% |
| | Red | On | PoE Load 71 - 90% |
| | Red | Flashing | PoE Load 91 - 100% |
| | Note: The Max. PoE output of this switch is 120 Watts. | | |
| LAN Port 1~16 | Green | On | Connected to the network, 1000Mbps |
| | | Flashing | Networking is active |
| | | Off | Not connected to the network |
| | Amber | On | Connected to the network, 10/100Mbps |
| | | Flashing | Networking is active |
| | | Off | Not connected to the network |

| | | | |
|-----|-------|-----|---------------------------------------|
| PoE | Amber | On | Supplying power to the powered-device |
| | | Off | Not connected to a powered device |

Table 2.1 - LED Indicators

Note: "P1" is the abbreviation for "Power 1", "P2" is for "Power 2", "LNK" is for "Link", and "ACT" is for "Activity".

2.4 Reset to Default

Please perform the steps below to reset the switch to factory default setting.

Step 1: Reverse the Tx & Rx of the console cable and plug it into the console port.

Step 2: Restart the power.

Step 3: The switch will start rebooting with the port LEDs flashing.

Step 4: When the status LED turns Green, the process is completed.

Step 5: Remove the reversed console cable.

2.5 Ethernet Ports

- **M12 Interface (Auto MDI/MDI-X)**
 - Connection Format: M12 8-Pin X-Coded Female Connector
 - Transmission rate: 10/100/1000Mbps

Prepare the M12 8-Pin X-Coded Ethernet Port mating cable for Ethernet connection. The M12 X-Coded Ethernet ports are auto-sensing for 10Base-T, 100Base-TX, or 1000Base-T devices connections. Auto MDI/MDI-X means that you can connect to another switch or workstation without changing straight-through or crossover cabling. See pin assignment shown in Table 2.2.

| M12 8-Pin X-Coded Female Connector | | | |
|---|---------|------------------------|-------------------|
|  | Pinouts | 10/100Base-T(X) Signal | 1000Base-T Signal |
| | 1 | Transmit Data + (TX+) | BI_DA+ |
| | 2 | Transmit Data - (TX-) | BI_DA- |
| | 3 | Receive Data + (RX+) | BI_DB+ |
| | 4 | Receive Data - (RX-) | BI_DB- |
| | 5 | | BI_DD+ |
| | 6 | | BI_DD- |
| | 7 | | BI_DC- |
| | 8 | | BI_DC+ |

Table 2.2 - Ethernet port pinouts

Note: "+" and "-" signs represent the polarity of the wires that make up each wire pair.

• **Connection of Cables**

Use the twisted-pair cable, category 5e or the above cabling for M12 port connections. The cable between the Ethernet switch and the link partner (switch, hub, workstation, etc.) must be less than 100 meters (328 ft.) long.

- Minimum Wire Gauge: 24AWG
- Maximum Transmission Length: 100m (328ft)



Caution: Please use copper conductors only.

Attention: Veuillez utiliser uniquement des conducteurs en cuivre.



Caution: Use conductors with insulation rated for at least 60°C.

Attention: Utilisez des conducteurs dont l'isolation est d'au moins 60°C.



Caution: Base the conductor ampacity on a maximum termination temperature of 60°C.

Attention: Basez l'intensité du conducteur sur une température de terminaison maximale de 60°C.

2.6 USB Port

- It is a M12 4-Pin A-Coded female connector
- USB Port is for configuration backup / restore
- M12 connector

| M12 4-Pin A-Coded female connector | | |
|---|---------|----------|
|  | Pinouts | Function |
| | 1 | DN |
| | 2 | VBUS |
| | 3 | GND |
| | 4 | DP |

Table 2.3 - USB port pinouts

2.7 Console Port

- It is an M12 5-Pin A-Coded female connector
- Baud rate 115, 200bps, 8, N, 1
- M12 connector

| M12 5-Pin A-Coded female connector | | |
|---|---------|----------|
|  | Pinouts | Function |
| | 1 | NC |
| | 2 | TX |
| | 3 | RX |
| | 4 | NC |
| | 5 | GND |

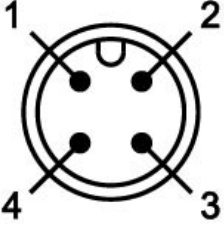
Table 2.4 - Console port pinouts

2.8 Power Inputs

This industrial Ethernet switch provides dual DC power inputs for redundancy through the M12 5-pin K-Coded male connector. Prepare the M12 5-pin K-Coded cable for power connection. *Table 2.5* shows the pin assignment.

| M12 5-Pin K-Coded Male Connector | | |
|---|---------|----------|
|  | Pinouts | Function |
| | 1 | V1+ |
| | 2 | V1- |
| | 3 | V2- |
| | 4 | V2+ |
| | 5 | GND |

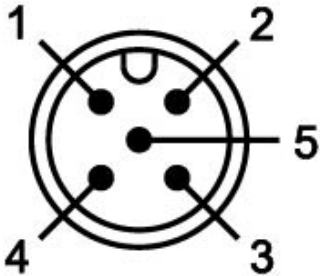
Table 2.5 - Power input pinouts

- **Connection of Cables**
 - Minimum Wire Gauge: 18AWG

Please follow the steps below to insert the power wire.

Step 1: Insert the positive and negative power wires into the power connector on the industrial Ethernet switch with Power 1 (V1+, V1-), and Power 2 (V2+, V2-).

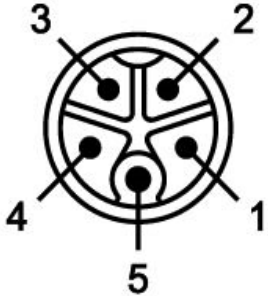
Step 2: Tighten the screw nut to prevent the connector from loosening.

2.9 Relay Contact and Digital Input

The Ethernet switch is equipped with an M12 5-Pin A-Coded Male connector with a normally closed relay contact for fault alarm and digital input (DI). The pin assignment of this connector is shown in *Table 2.6*.

| M12 5-Pin A-Coded Male Connector | | | |
|---|---------|------------------|-----------------|
|  | Pinouts | Function | Description |
| | 1 | DI+ Relay Com | Common |
| | 2 | DI+ | Digital Input + |
| | 3 | DI- | Digital Input - |
| | 4 | DI- Relay (N.C.) | Normally Closed |
| | 5 | NA | Not Assigned |

Table 2.6 - Relay and DI pinouts

- **Connection of Cables**

- Minimum Wire Gauge: 24AWG

- **Relay Contact**

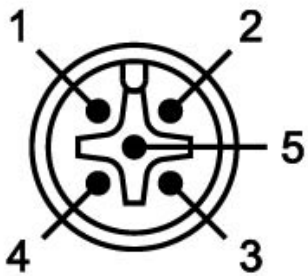
Relay is opened if any event listed below happens:

1. The current PoE outputs of all connected PDs exceed 240 Watts (for PoE models)
2. Power 1 or Power 2 was inactive
3. If anyone of all PoE ports exceeds 30 Watts (for PoE models)
4. Event happened by software setting

Relay is closed under the conditions below:

1. No event after reboot
2. No event after reset the switch

A connection of relay contact for fault alarm is shown below in *Figure 2.5*.

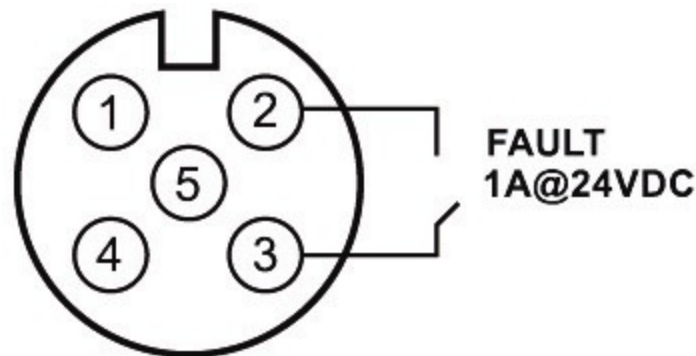

Figure 2.5: Wiring the relay contact for fault alarm

When the Ethernet switch is operating normally, the relay contact is a closed circuit. When the switch has any fault status (PoE overload or power failure), the relay contact circuit is opened and the FAULT LED lights up. In addition, even after the abnormal situation has been removed, the relay contact is still open and the FAULT LED remains active, unless using the digital input to reset that. See the next section for information on Digital Input.

- **Digital Input (DI)**

The digital input is used for monitoring two external events via an external voltage source. When the voltage level on digital input pins changes from high voltage to low voltage, the DI function will be triggered. *Table 2.7* is shown a detailed specification of the digital input.

| Specification | | Description |
|-----------------------|---------------|--|
| Level 0 (Low) | -30~8VDC | Will trigger DI function (active trigger states) |
| Level 1 (High) | 10~30VDC | Normal Status (inactive trigger states) |
| Nominal input voltage | 24VDC | |
| Max. input voltage | 30VDC | |
| Nominal input current | 5mA (typical) | |
| Max. input current | 8mA | |

Table 2.7 - Specification of DI

As described in the Relay Contact section, if the fault status (total output power over device's PoE power budget, or any one of PoE ports over 30 Watts) happens, you have to use DI function to reset the Fault LED, so there are two DI functions this unit supports for manually reset or reboot the device, which is shown as follows.

1. When the trigger time < 4 seconds, the relay contact will be reset and the Fault LED light down.
2. When the trigger time > 4 seconds, the Ethernet switch will be rebooted.

2.10 Grounding Note

Grounding and wire routing help limit the effects of noise due to electromagnetic interference (EMI). Run the ground connection from the ground screw to the grounding surface prior to connecting devices. The grounding screw symbol is shown below in *Figure 2.6*.

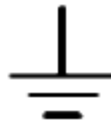

Figure 2.6 - Grounding Screw Symbol

2.11 Bypass Function

This Ethernet switch supports bypass function by two Ethernet ports (P8 and P16). When one of the Ethernet switches loses power, Ethernet ports (P8 and P16) will bypass the power lost Ethernet switch to prevent the network from disconnecting.

Take *Figure 2.7* for example, if Switch B has power failure, the bypass function will be activated automatically, and it will bypass Switch B and bridge P8 to P16 of Switch B, so that the data transmission path (from Switch A to C) can remain connected and unaffected.

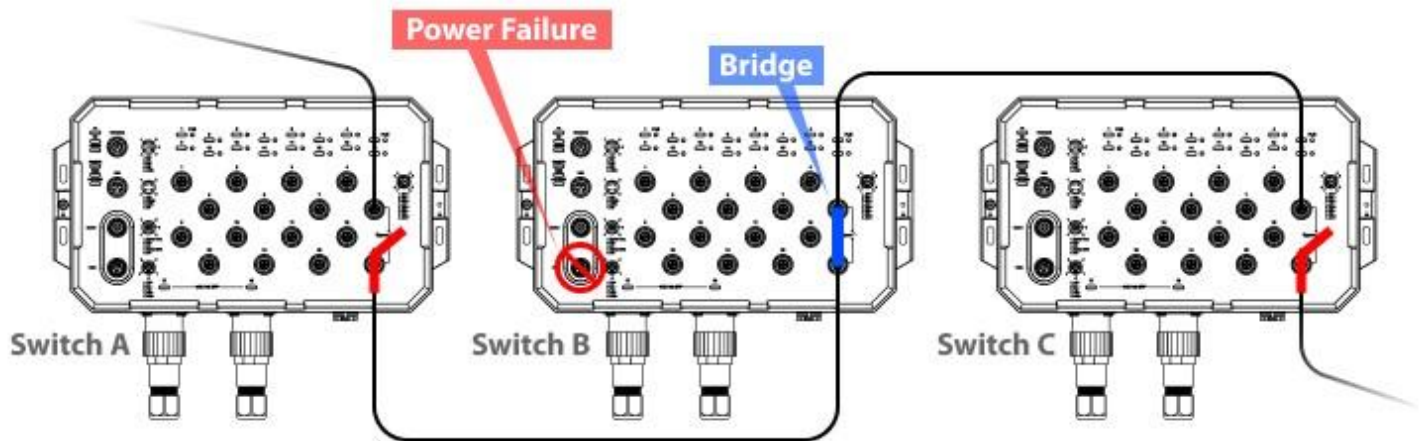

Figure 2.7 - Example of Bypass Function

3 Mounting Installation

3.1 Wall Mounting

Follow the steps below to mount the industrial Ethernet switch to a wall using the screw holes as shown below in *Figure 3.1*.

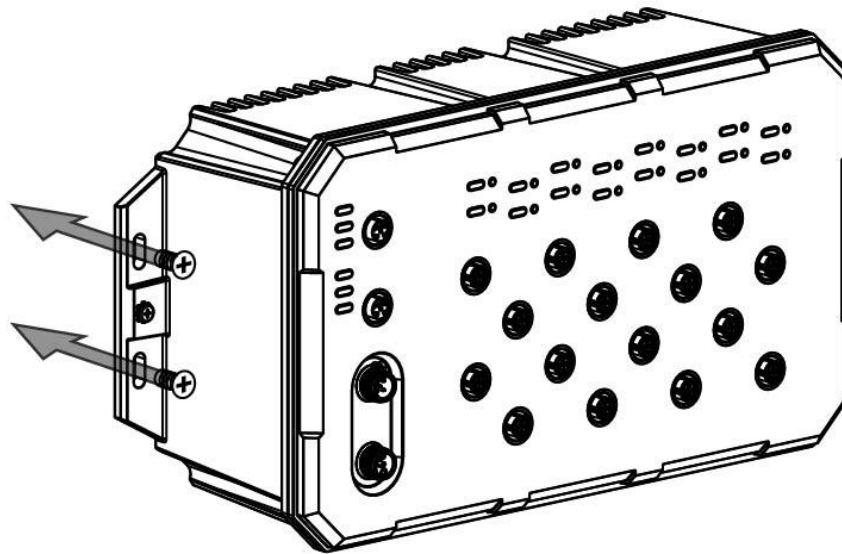

Figure 3.1 - The Rear Side of the Switch

Follow the steps below to learn how to hang the industrial Switch.

Step 1. Prepare 4 screws for mounting the switch to a wall.

Note: Recommended use of the M5 screws.

Step 2. Based on the *Figure 2.1: Physical Dimensions* which is shown the positions of 4 screw holes on the left and right side of the switch to make 4 screw holes on a wall accordingly.

Step 3. Insert the screws through the screw holes on the switch and screw the switch into the wall. Shown above in *Figure 3.1*.

Step 4. To remove the switch from the wall, do the opposite from the steps above.

Note: Make sure to disconnect all cables from the switch before removing the unit from the wall.

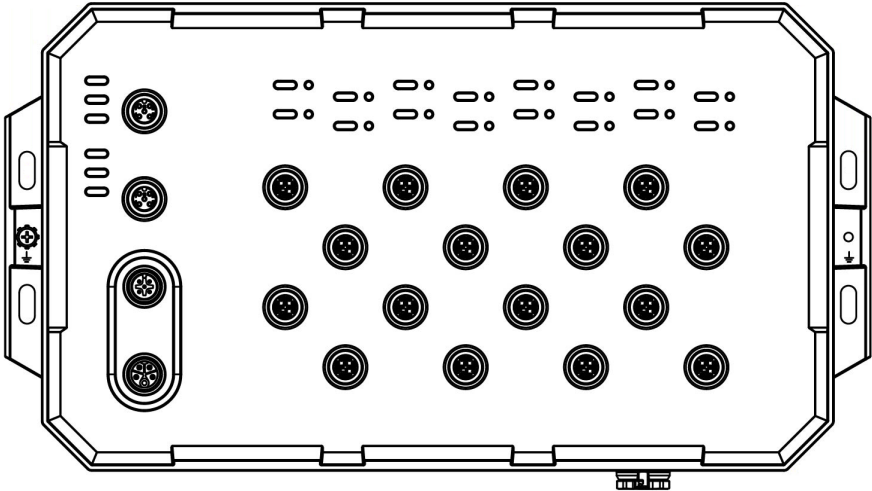

Figure 3.2 - Position of the screw holes

4 Hardware Installation

4.1 Installation Steps

This section will explain how to install the industrial Ethernet switch:



Caution: This device is intended for indoor use.



Attention: Cet appareil est destiné à une utilisation en intérieur.



Caution: The device is intended to be installed in an industrial control enclosure and panel.



Attention: L'appareil est destiné à être installé dans une armoire de commande et un panneau industriels.

Installation Steps

1. Unpack the industrial Ethernet switch from the original packing box.
2. To hang the industrial Ethernet switch on a wall, please refer to the Mounting Installation section.
3. Power on the industrial Ethernet switch and then the power LED light will turn on.
 - If you need help on how to wire power, please refer to the **Power Inputs** section.
 - Please refer to the **LED Indicators** section for LED light indication.
4. Prepare the M12 cable for Ethernet connection.
5. Insert one side of the M12 cable into the switch's Ethernet port and on the other side into the networking device's Ethernet port. The Ethernet port's (L/A) LED on the industrial Ethernet switch will turn on when the cable is connected to the networking device.
 - Please refer to the **LED Indicators** section for LED light indication.
6. When all connections are set and the LED lights all show normal, the installation is complete.

4.2 Maintenance and Service

- If the device requires servicing of any kind, the user is required to disconnect and remove it from its mounting. The initial installation should be done in a way that makes this as convenient as possible.
- Voltage / Power lines should be properly insulated as well as other cables. Be careful when handling them so as to not trip over.
- Do not under any circumstance insert foreign objects of any kind into the heat dissipation holes located in the different faces of the device. This may not only harm the internal layout, but might cause harm to users as well.
- Do not under any circumstance open the device for any reason. Please contact your dealer for any repair needed or follow the instructions within the manual.
- Clean the device with dry soft cloth.

4.3 Troubleshooting

- Always verify the right power cord or adapter is being used. Never use a power supply or adapter with a non-compliant DC output voltage or it will burn the equipment.
- Diagnosing LED Indicators: To assist in identifying problems, the switch can be easily monitored with the LED indicators which help to identify if any problems exist.
 - Please refer to the LED Indicators section for LED light indication.
- If the power indicator LED does not turn on when the power cord is plugged in, the user may have a problem with the power cord. Check for loose power connections, power losses or surges at the power outlet.
 - Please contact Antaira for technical support service if the problem still cannot be resolved.
- If the industrial switch LED indicators are normal and the connected cables are correct but the packets still cannot transmit, please check the system's Ethernet devices' configuration or status.

5 Technical Specifications

Table 5.1 has the technical specifications for this product series.

| Technology | |
|-----------------------------|--|
| L2 Switching | Port/MAC/Protocol/IP Subnet-based VLAN, GARP/GVRP, Loop Guard, Link Aggregation static/LACP, BPDU guard, Error disable recovery, IGMP snooping v2/v3, MLD snooping v1/v2, IGMP filtering, IPMC throttling / filtering leave proxy, DHCP snooping, G.8032 v1/v2 |
| L3 Switching | DHCP option82, static routes |
| QoS | 802.1p Queueing, Input priority mapping, Storm control for Unicast/Multicast/Broadcast, Port/Queue/ACL policer, Port egress shaper, Queue egress shaper, DiffServ (DSCP), Tag remarking, Scheduler mode |
| Power Saving | ActiPHY, PerfectReach, IEEE 802.3az EEE power management |
| Network Redundancy | STP/RSTP/MSTP, port trunk with LACP, ERPS v1/v2 (<50ms) |
| Configuration | Http, Https, Telnet, SSH, CLI, TFTP, SNMP v3 |
| System / Diagnostics | Dual Image Protection, PING, PING6 |
| Switch Properties | |
| Switch Architecture | Back-Plane (Switching Fabric): 32.0Gbps |
| Priority Queues | 8 |
| Processing Type | Store and Forward |
| Flow Control | IEEE 802.3x for full-duplex mode, back pressure for half-duplex mode |
| Transfer Rate | 14,880pps for 10Base-T Ethernet 148,800pps for 100Base-T Fast Ethernet 1,488,000pps for Gigabit Ethernet 14,880,000pps for 10 Gigabit Ethernet |
| Memory Buffer | 4Mbits |
| Jumbo Frame | 9.6Kbytes |
| MAC Table Size | 32K |
| VLAN Group | 4095 |
| IGMP Group | 1024 |
| Port Interface | |
| Ethernet Port | 16*10/100/1000BaseTx, 8-pin M12 X-Coded female connectors Auto-negotiation speed, Full/Half duplex mode, and auto MDI/MDI-X |

Antaira Technologies - Industrial Ethernet Switches
LMP-1600G-M12-67-110 Series - Hardware Manual - v1.0

| | |
|------------------------------------|--|
| | connection |
| RS232 Serial Console | 1*RS232 with M12 5-pin A-coded female connector |
| Configuration Backup | 1*USB 2.0 with M12 4-pin A-coded female connector for configuration backup/restore |
| DI | 1* Digital Input (DI): State 0: -30~8VDC / State 1: 10~30VDC, Max. input current: 8mA |
| Bypass Protection | Ethernet Port 8 and Port 16 |
| LED Indicators | System: Power 1, Power 2, Master, Ring, Status, PoE Load PoE: On-connected to PD devices Ethernet ports: Speed/Link/Active |
| Protection | |
| Network Cable | 10Base-T: 2-pair UTP/STP Cat. 3, 4, 5 cable; EIA/TIA-568 100-ohm (100m) 100Base-TX: 2-pair 2-pair UTP/STP Cat. 5 cable; EIA/TIA-568 100-ohm (100m) 1000Base-TX: 4-pair UTP/STP Cat. 5/5E cable; EIA/TIA-568 100-ohm (100m) |
| Mechanical Characteristics | |
| Housing | Metal, IP67 rated |
| Dimensions | 166.2 x 295 x 101.3 mm (W x H x D) |
| Weight | Unit: 9.41 lbs. Shipping: 11.01 lbs. |
| Mounting | Wall mounting |
| Power Requirement | |
| Input Voltage | 24~110VDC Redundant Input |
| Power Connection | Dual DC power inputs through M12 5-pin K-coded male connector |
| Relay Contact | 24VDC, 1A resistive |
| Overload Current Protection | Present |
| Reverse Polarity Protection | Present |
| PoE Pin Assignment | V+, V+, V-, V- for pin 1, 2, 3, 6 (End-span, Mode A) |
| PoE Power Budget | 120W |
| System Power Consumption | 45 Watts |
| Environmental Limits | |
| Operating Temperature | STD: -10°C to 65°C EOT: -40°C to 70°C |

Antaira Technologies - Industrial Ethernet Switches
LMP-1600G-M12-67-110 Series - Hardware Manual - v1.0

| | |
|----------------------------------|---|
| Storage Temperature | -40°C ~ 85°C |
| Ambient Relative Humidity | 5 to 95%, (non-condensing) |
| Regulatory Approvals | |
| EMI | FCC Part 15 Subpart B Class A CE EN55032/EN61000-6-4 Class A |
| EMS | CE EN55035/EN61000-6-2 EN61000-4-2,3,4,5,6,8 |
| Free Fall | IEC60068-2-32 |
| Shock | IEC60068-2-27 |
| Vibration | IEC60068-2-6 |
| Green | RoHS Compliant |
| Certifications | FCC, CE |
| Warranty | 5 Years |

Table 5.1 - Technical Specifications

Antaira Customer Service and Support

(Antaira US Headquarter) + 844-268-2472

(Antaira Europe Office) +48-22-862-88-81

(Antaira Asia Office) +886-2-2218-9733

Please report any problems to Antaira:

www.antaira.com / support@antaira.com

www.antaira.eu / info@antaira.eu

www.antaira.com.tw / info@antaira.com.tw

Any changes to this material will be announced on the Antaira website.